

ADME models in the drug discovery pipeline

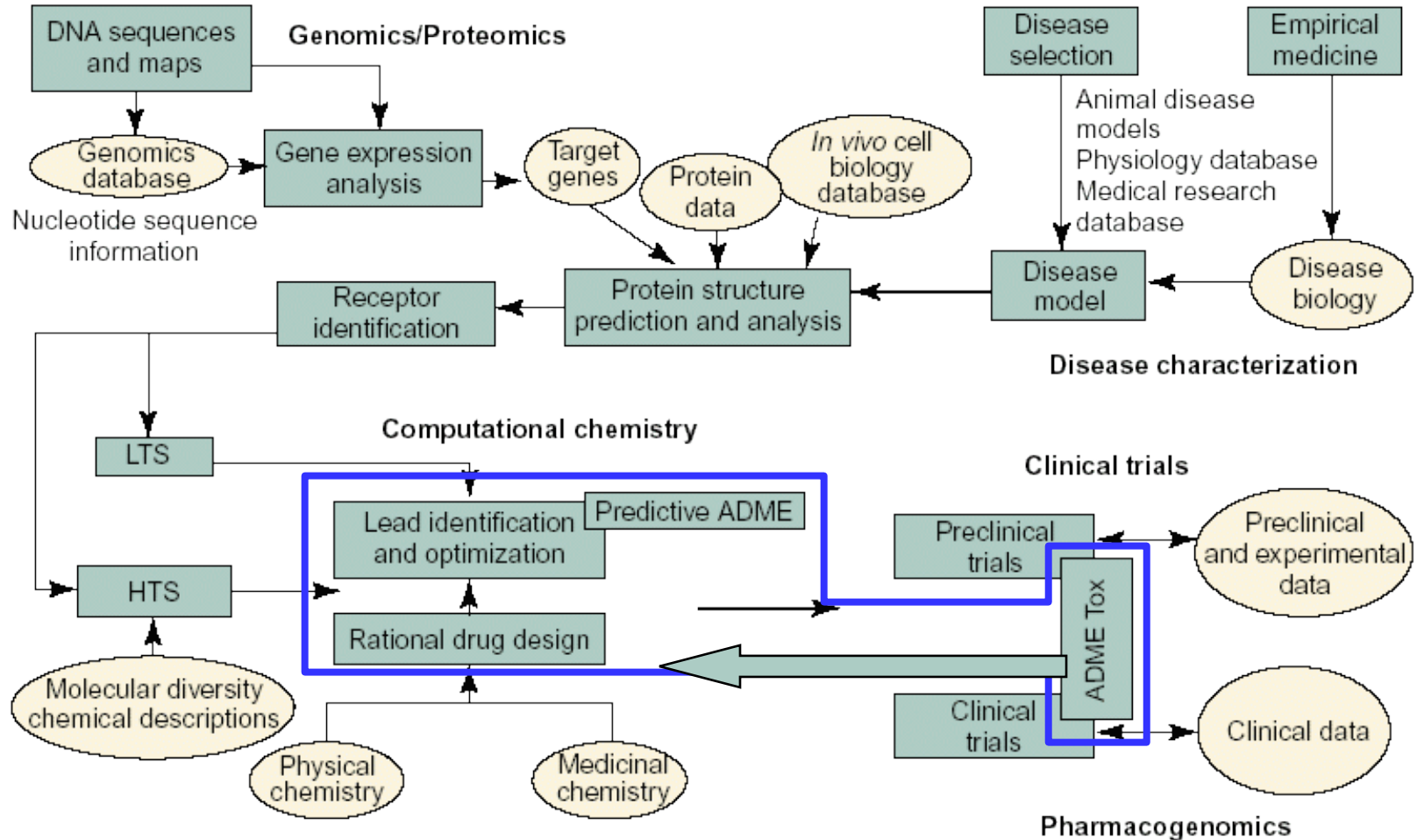

eADMET prediction

early
Absorption
Distribution
Metabolism
Elimination
Toxicology



Pharmacokinetic
Bioavailability

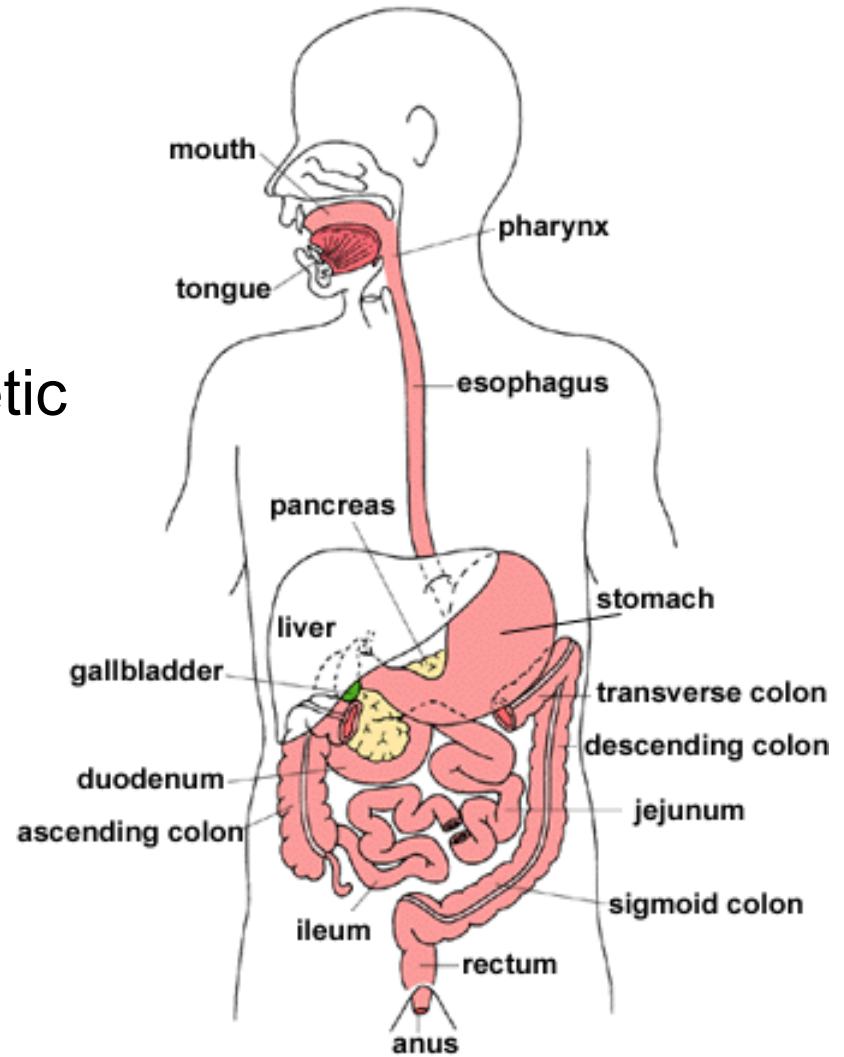

ADME models (I)

Following models are useful for *in silico* design:

primary models

solubility

intestinal absorption

bioavailability

metabolic stability

blood-brain-barrier permeation

mutagenicity

cardial toxicity (*hERG-channel*)

plasma protein binding

secondary models

transport (uptake and efflux)

common toxicity

hepatotoxicity (*PXR, CAR*)

nephrotoxicity

immunotoxicity

neurotoxicity (receptor binding)

drug-drug interactions

(*Cytochrome P450*)

Covered in [this lecture](#) and the [upcomming lectures](#)

ADME models (II)

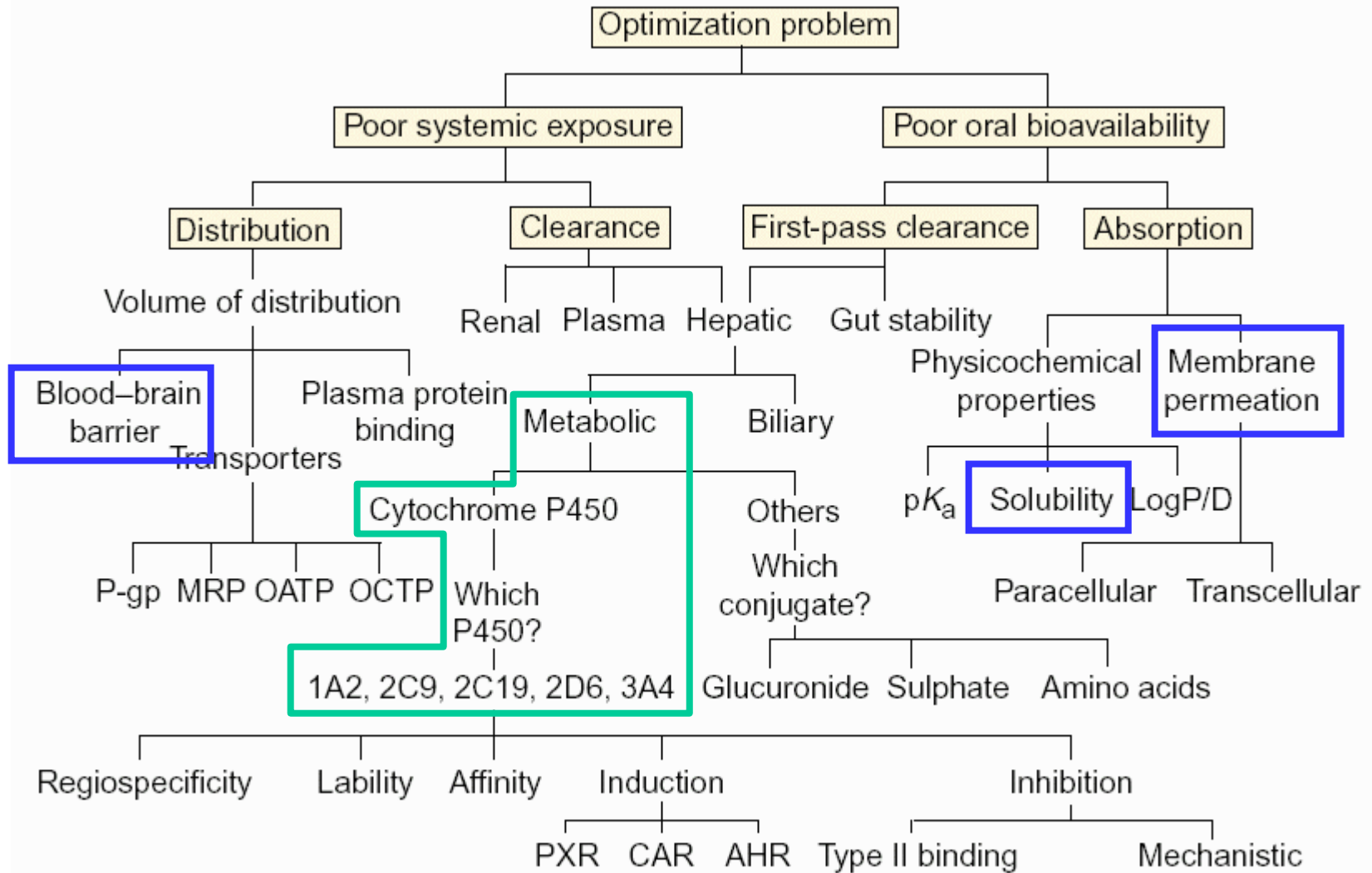

Why is ADME prediction that important ?

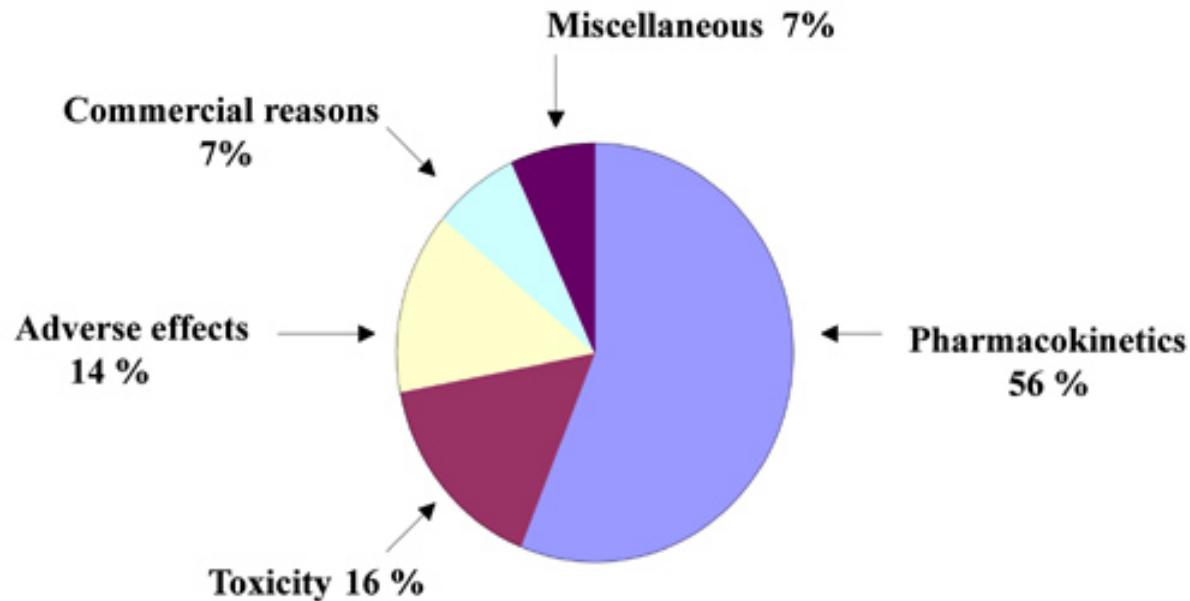

Reasons that lead to failure or withdrawal of a potential drug around 1995 – 2000

Why is ADME prediction that important ? (II)

Our aim is to recognize unsuitable compounds as soon as possible:

- saving resources
- avoiding unnecessary clinical trials
- The later a drug has to be withdrawn, the more expensive it gets.

„Fail early, fail fast, fail cheap“



Compound selection for the High Throughput Screening (HTS)

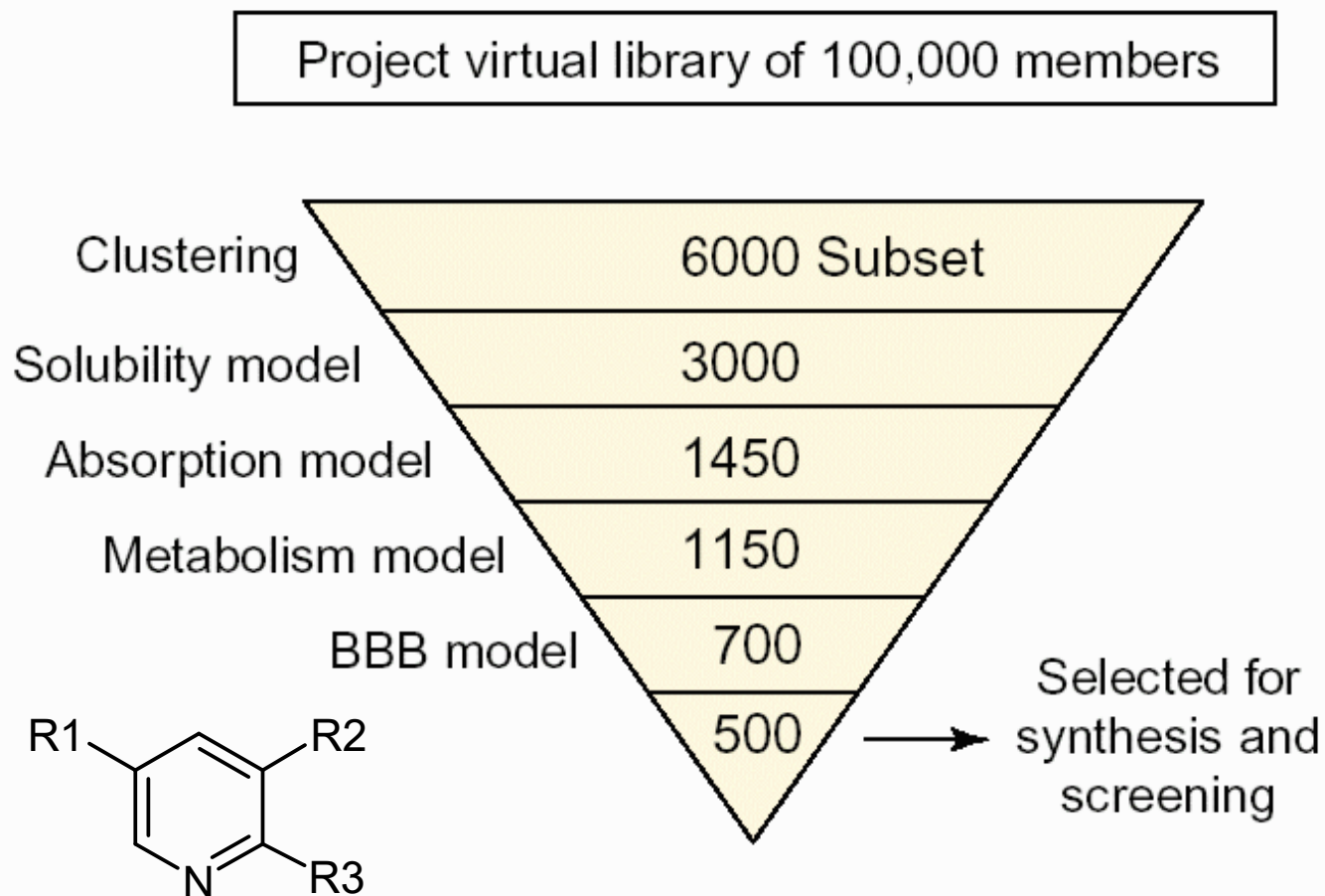

Drug Discovery Today

typical eADME filter

solvation versus solubility

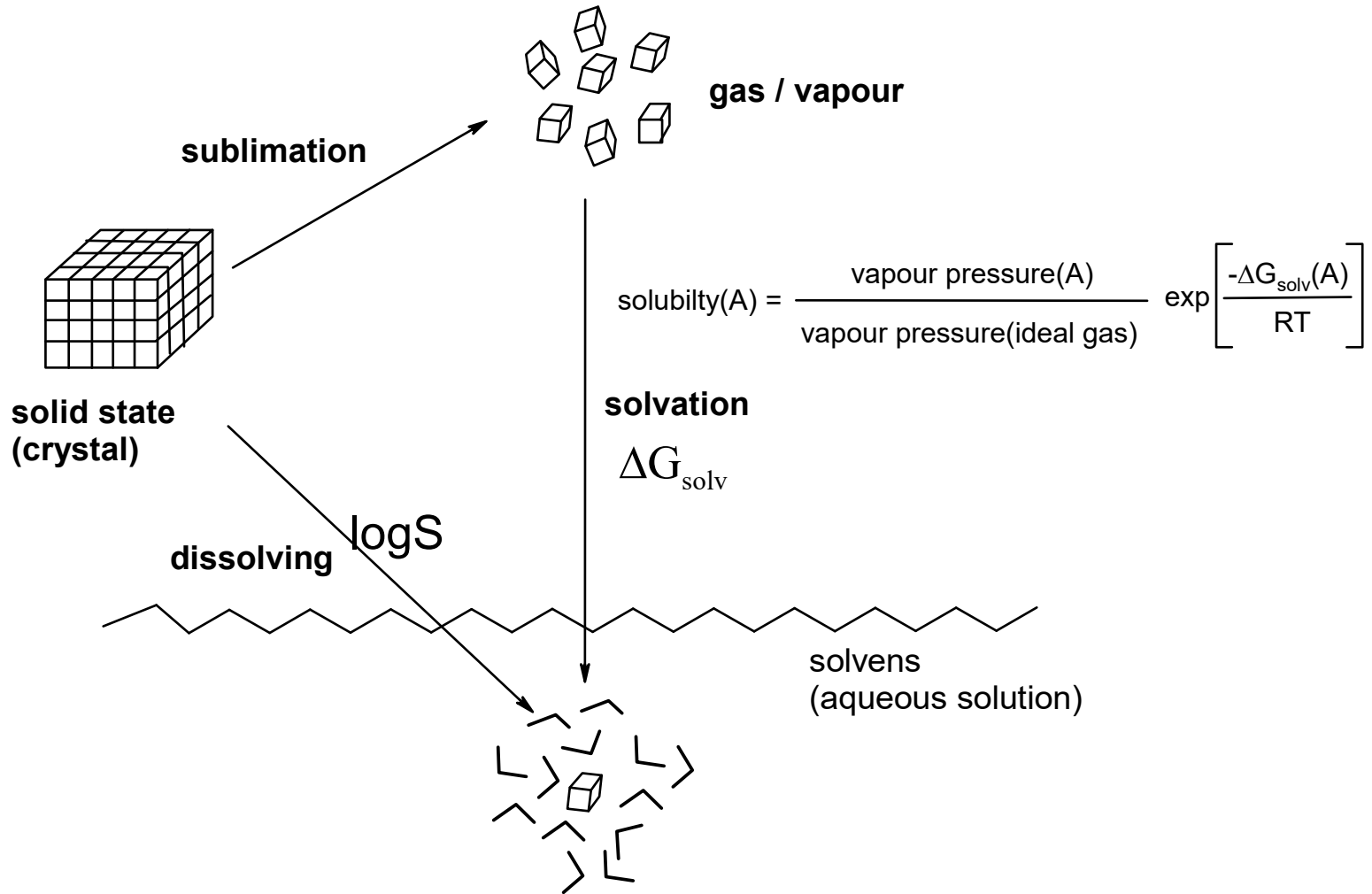

Solubility models (I)

Direct computation of the solubility from a thermodynamic cycle (lattice energy, heat of solvation) is possible, but

1. The prediction of the lattice energy by computational methods requires knowing the space group of the crystal
2. Computation of the heat of solvation is errorprone itself

Thus, mainly QSAR approaches are applied.

However, automated workflows that derive specifically tailored force fields for the molecule at hand exist, although these are computationally very demanding.

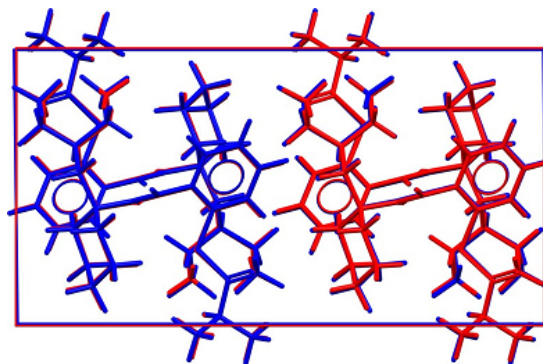

Lit: Neumann MA et al. *Nat. Commun* **6** (2015) 7793.

Reilly et al. *Acta Cryst. B* **72** Pt4 (2016) 439-459.

Solubility models (II)

descriptors: connectivity indices

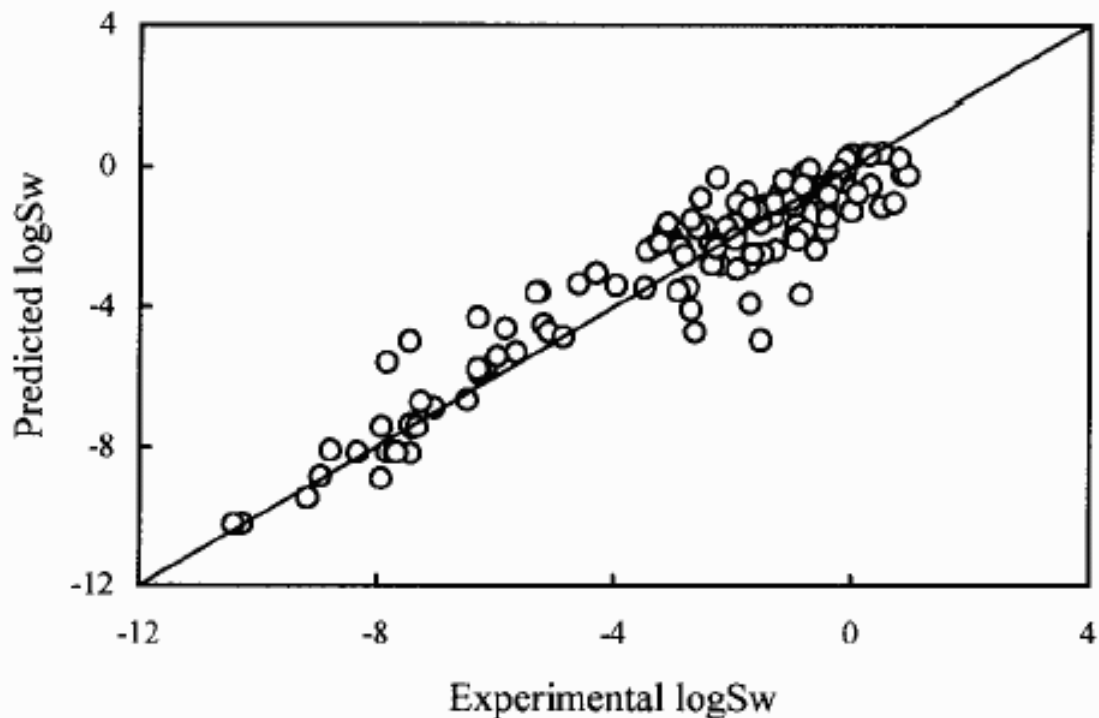

$$r^2=0.89, q^2= 0.84, se = 0.98, n=120, F=297.80$$

Lit. C. Zhong et al. *J.Pharm.Sci.* **92** (2003) 2284

Solubility models (III)

Further approaches show that the applied descriptors must account for lipophilic and H-bond properties, as well as the flexibility of the compounds

Lit: A. Cheng et al. *J.Med.Chem.* **46** (2003) 3572

D. Butina et al. *J.Chem.Inf.Comput.Sci.* **43** (2003) 837

Besides common QSAR equations, also machine learning approaches are used:

Lit: A. Yan et al. *J.Chem.Inf.Comput.Sci.* **43** (2003) 429

J.K. Wegener et al. *Ibid* **43** (2003) 1077

Z. Ye, D. Ouyang *J.Cheminf.* **13** (2021) 98

S. Lee et al. *ACS Omega* **7** (2022) 12268

Predicting the solubility of a compound in various solvents and solvent mixtures is likewise an issue for chemical synthesis.

Absorption

How much and how fast is a substance absorbed?

Drugs should be orally applicable for convenience



After passing the stomach, they are resorbed from the colon/intestine into the blood. Transport via the portal vein into the liver.

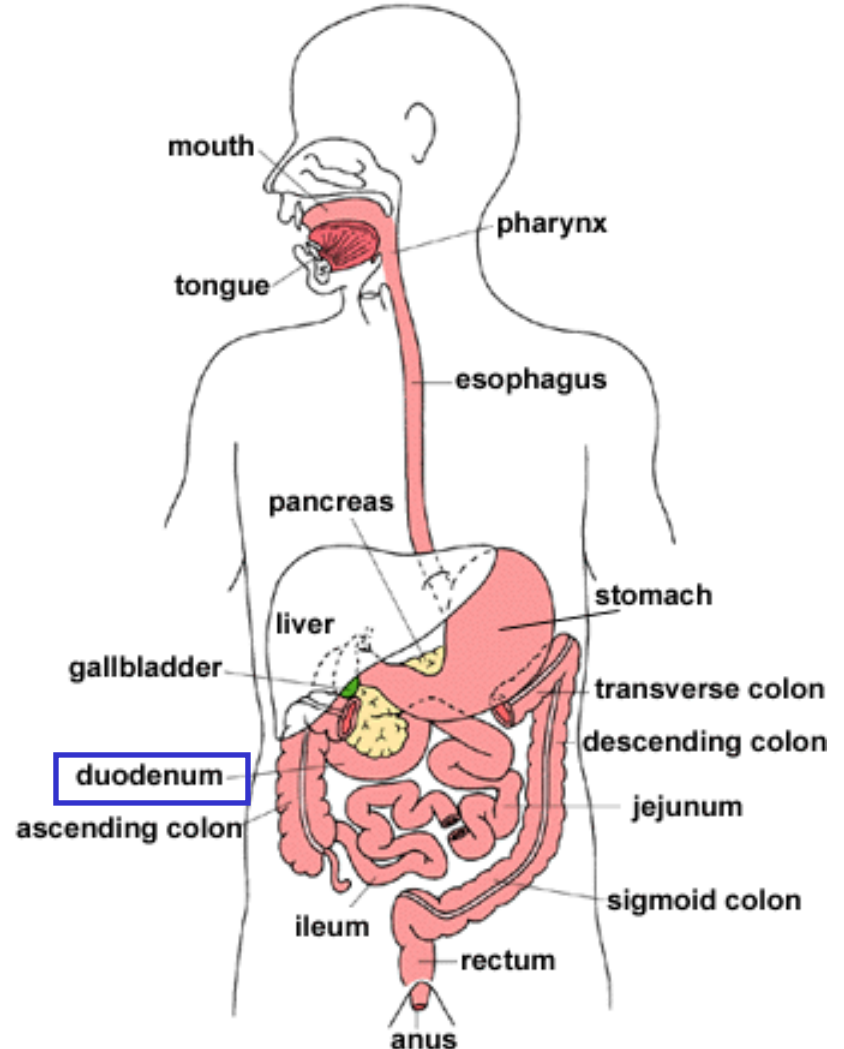

Absorption in the duodenum (I)

Uptake of a substance into the systemic circulation

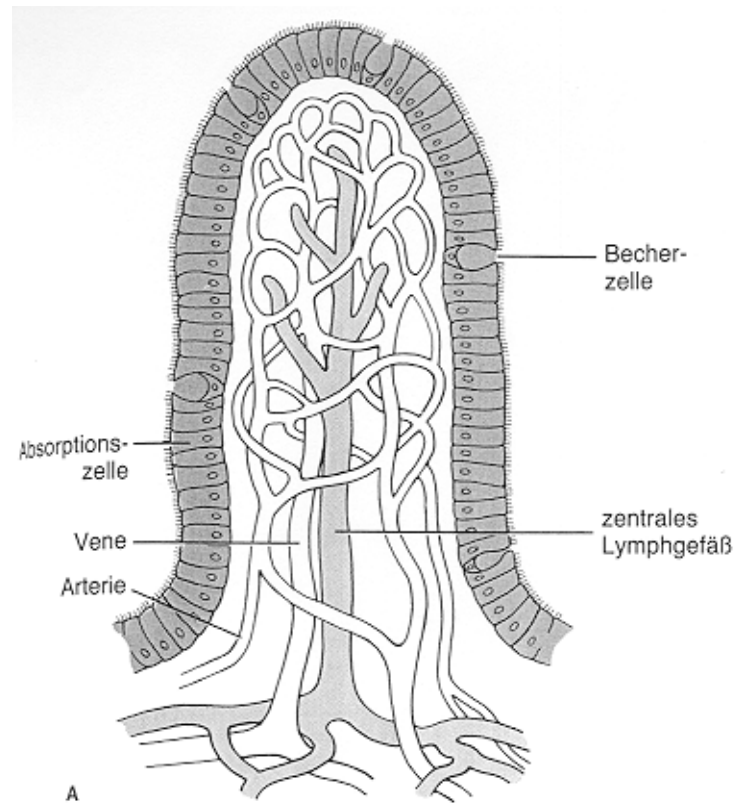

Cross-section from the colon wall

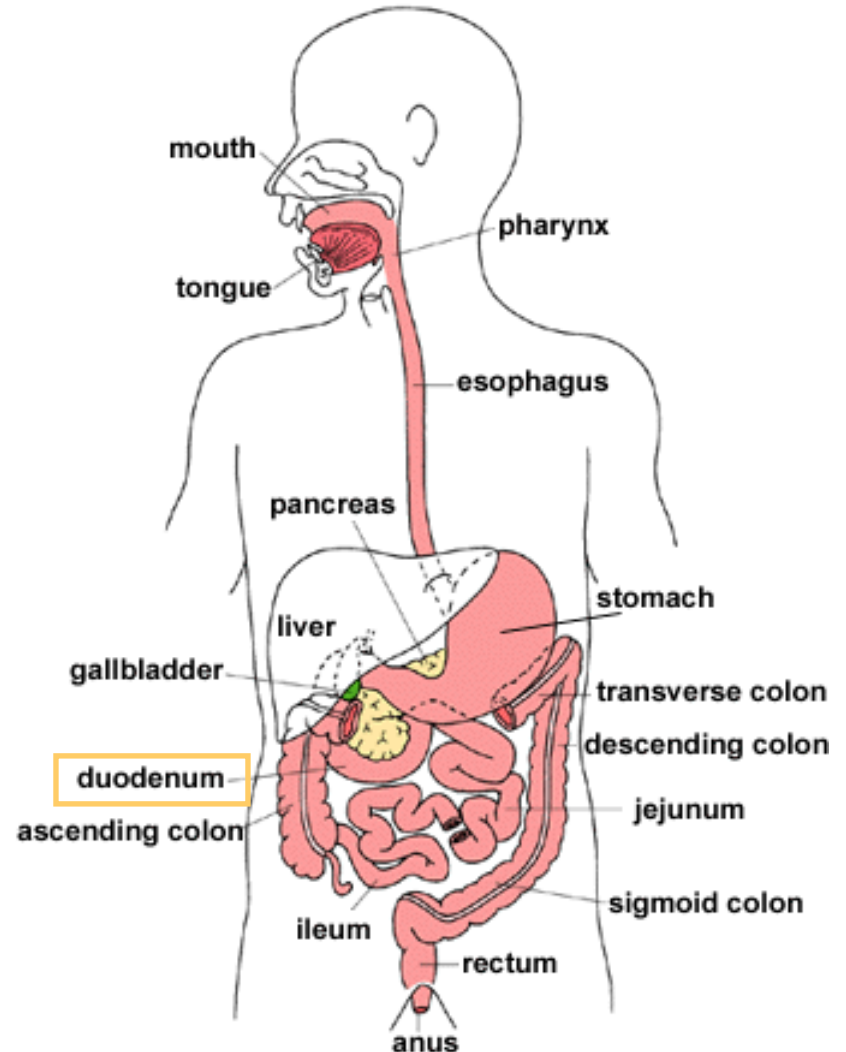

Absorption in the duodenum (II)

Uptake of a substance into the systemic circulation

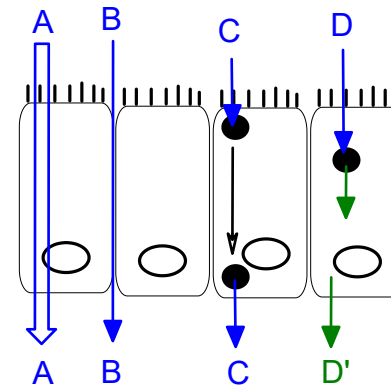
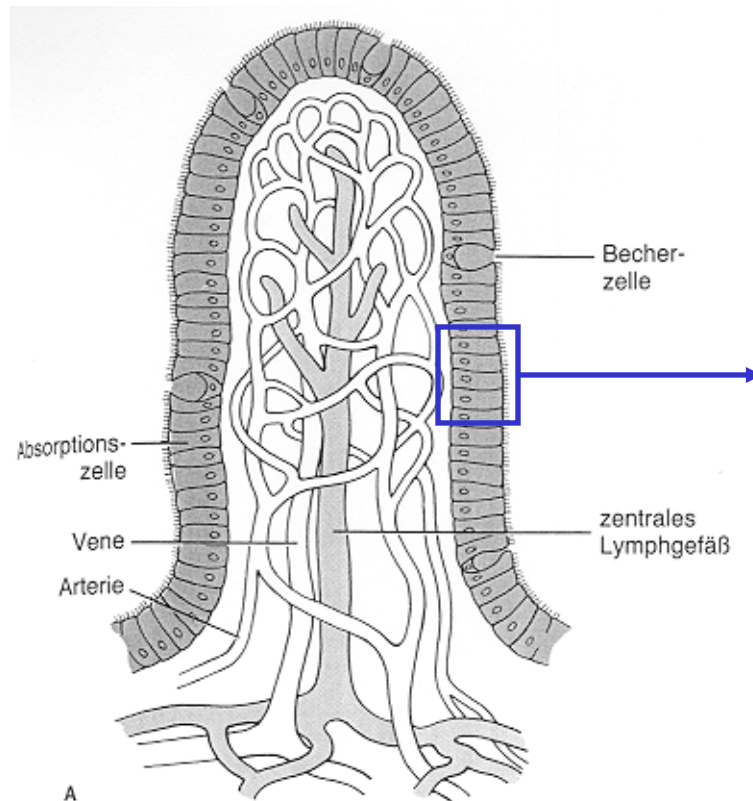

A transcellular (passive diffusion)

B paracellular

C active transport

D transcytosis

Cross-section from the
colon wall

Absorption in the duodenum (III)

model of the cellular membrane

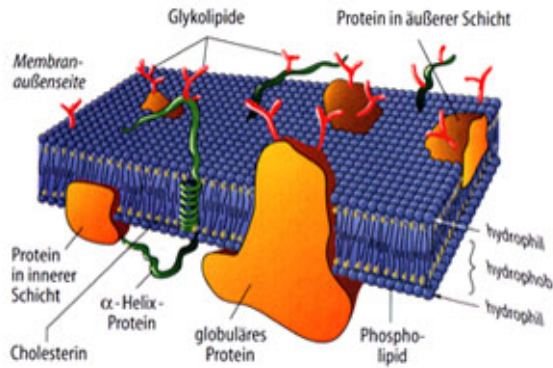

phospholipid

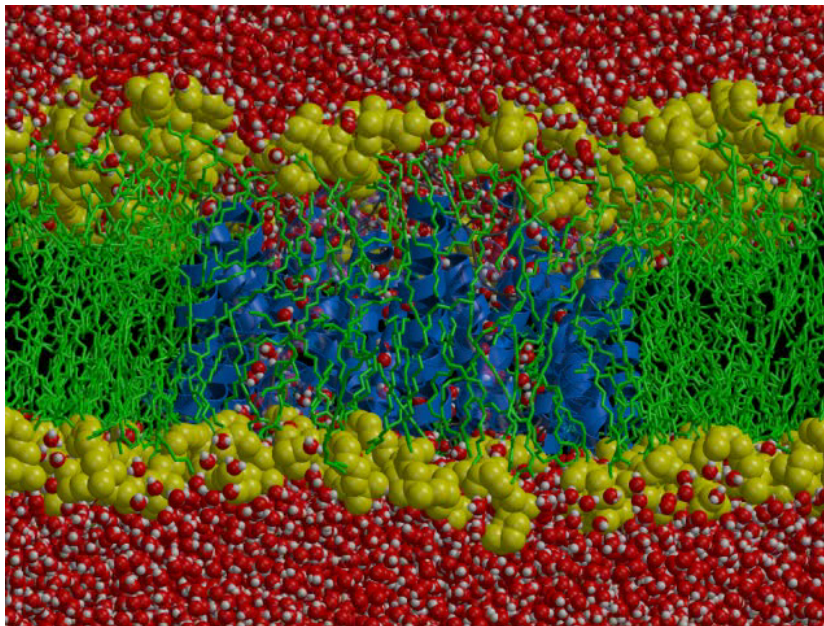
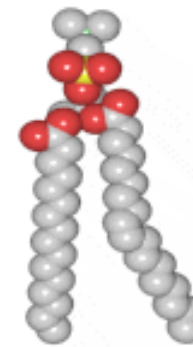

De Groot et al. *Science* **294** (2001) 2353

Caco-2 cell monolayer

Experimental approach for the prediction of intestinal absorption

monolayer of a culture of cells that are derived from a colon cancer

Advantage: reproducible results, in good agreement with *in vivo* studies

Disadvantage: these cells exhibit somewhat different metabolic properties than cells for the duodenum (MDR1 transporter = P-glycoprotein is over expressed, which leads to increased efflux of many substances)

Besides Caco-2 cells, also synthetic membranes are used for screening

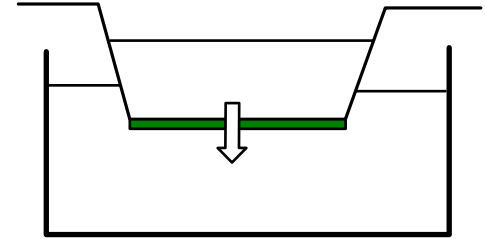

What factors determine the passive diffusion through lipid bilayers ?

Small molecules should pass through faster than large
descriptor: molecular weight (MW) and molecular shape

phospholipid bilayers are lipophilic on the inside

Thus, lipophilic molecules should pass through the interior faster
descriptor: logP (water/*n*-octanol partition coefficient)

phospholipid bilayers have a hydrophilic surface

descriptors: number of H-bond donors and acceptors

observation: the permeability is related to the heat of solvation

Descriptors derived from molecules to predict ADME properties

Frequently occurring in QSAR equations and machine learning algorithms are:

logP water/*n*-octanol partition coefficient

number of violations of Lipinski's rule of five

topological indices (e.g. from fingerprints)

polar surface area

count of polar atoms (can form hydrogen-bonds)

count of titratable groups (acids, bases)

count of halogen atoms (lipophilic)

Lit: S. Lee et al. *ACS Omega* **7** (2022) 12268

Lipinski's Rule of 5

Combination of descriptors to estimate intestinal absorption.
Insufficient uptake of compounds, if

Molecular weight > 500

slow diffusion

$\log P > 5.0$

too lipophilic

> 5 H-bond donors (OH and NH)

too many H-bonds with the

>10 H-bond acceptors (N and O atoms)

head groups of the membrane

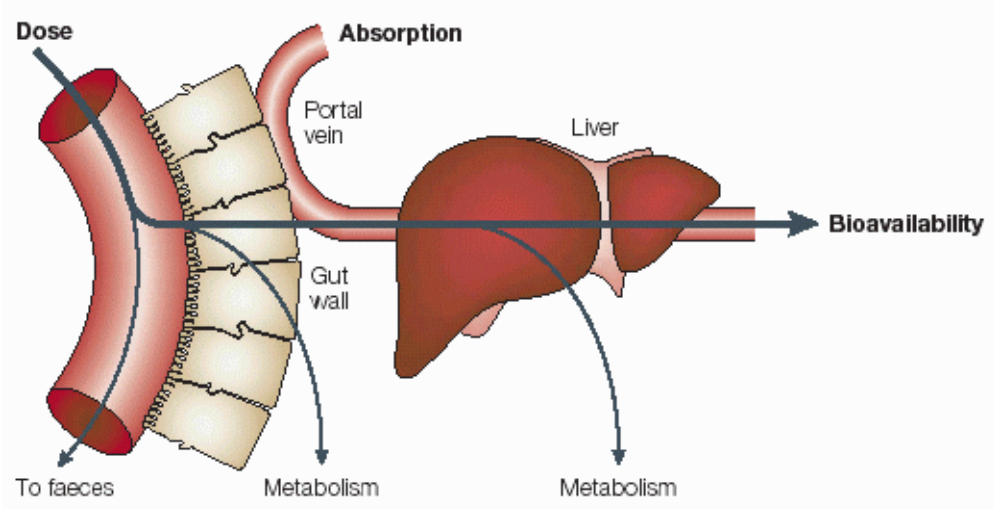

C.A. Lipinski et al. *Adv. Drug. Delivery Reviews* **23** (1997) 3.

Polar Surface Area (PSA)

The PSA is defined as the part of the molecular surface of a compound that stems from the nitrogen and oxygen atoms, as well as the polar hydrogens bonded to them.

= a quantitative measure for the ability to form H-bonds

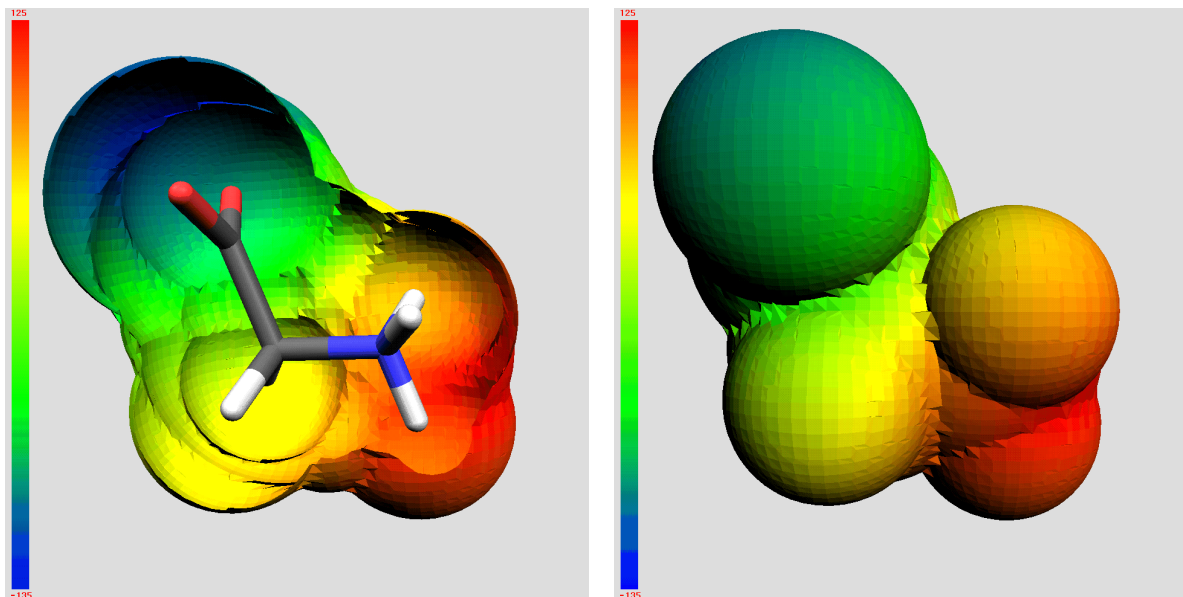

Like all other 3D descriptors the PSA is in general dependent from the conformation.

Models for absorption

New studies show, however, that there is a sound correlation between Caco-2 absorption and uptake (fractional absorption) in human (%FA) regardless of possible conformers.

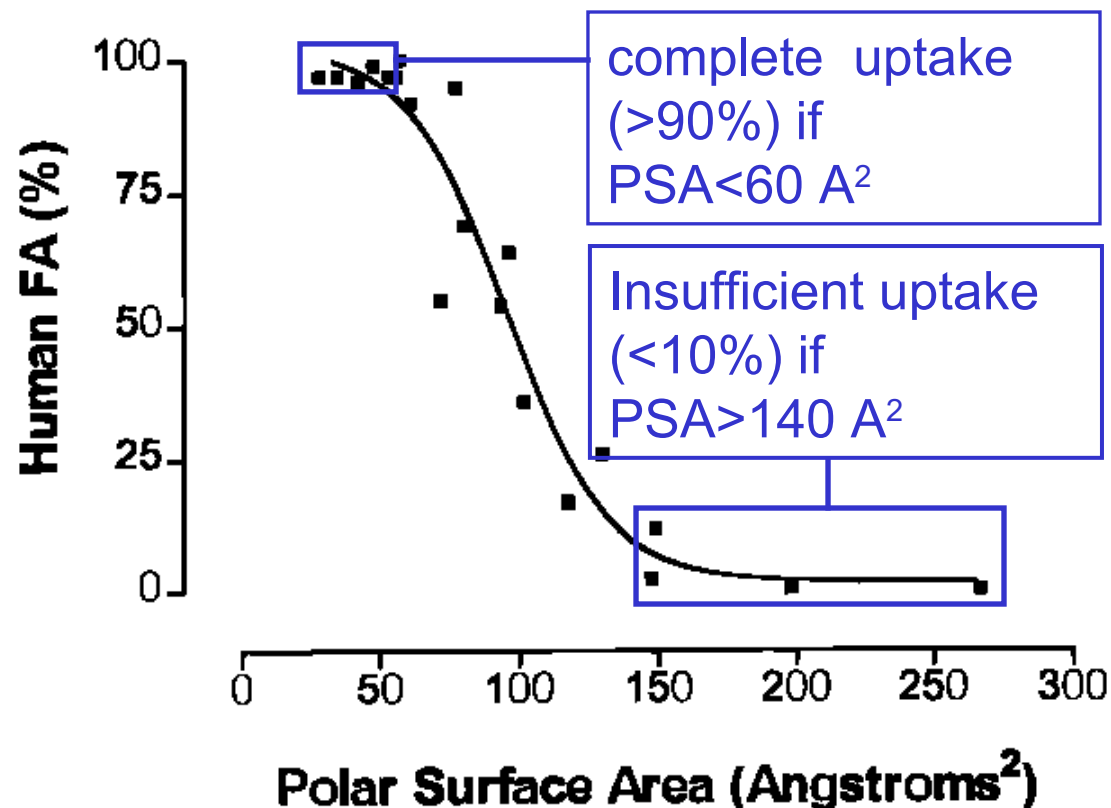

Lit: D.E. Clark, *J.Pharm.Sci.* **8** (1999) 807; *Drug Discovery Today* **5** (2000) 49;
K. Palm et al. *J.Med.Chem.* **41** (1998) 5382

Pharmacokinetic and Bioavailability

The body/organism is regarded as an open system that tries to restore the equilibrium after each disturbance/dosage

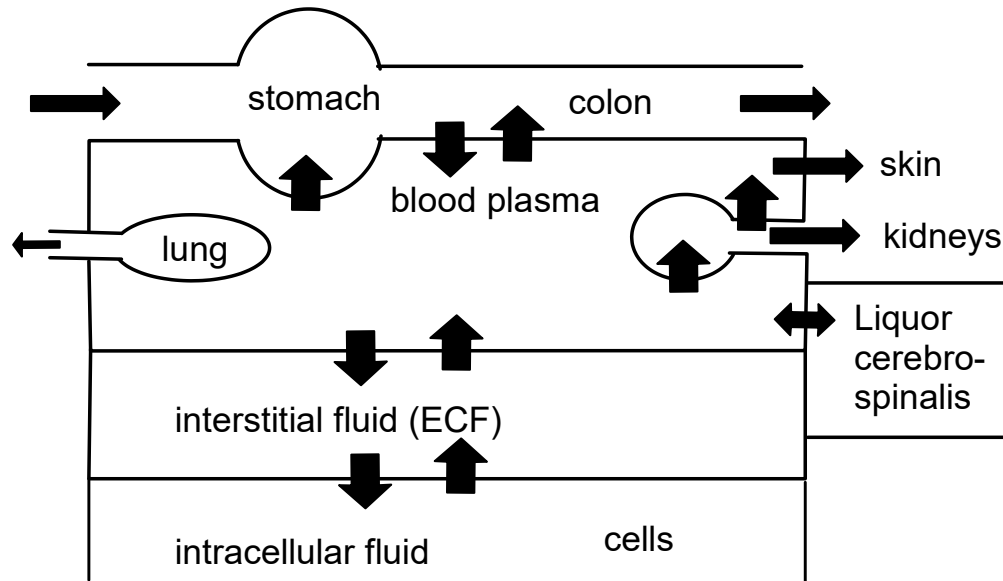

The body is partitioned into a series of compartments. Between these compartments there is a constant flow / exchange.

distribution / invasion

The total path of a substance can be separated into

- 1) diffusion in the solvent
- 2) diffusion through tissue and membranes
- 3) transport by the blood
- 4)
 - a) diffusion to the receptors
 - b) diffusion into other compartments
 - c) diffusion into elimination organs
- 5) irreversible elimination

} absorption

} invasion
(according to
Dost)
≈ distribution

High constant of elimination: short period anesthetics

Low constant of elimination: antibiotics

Volume of distribution and dosage

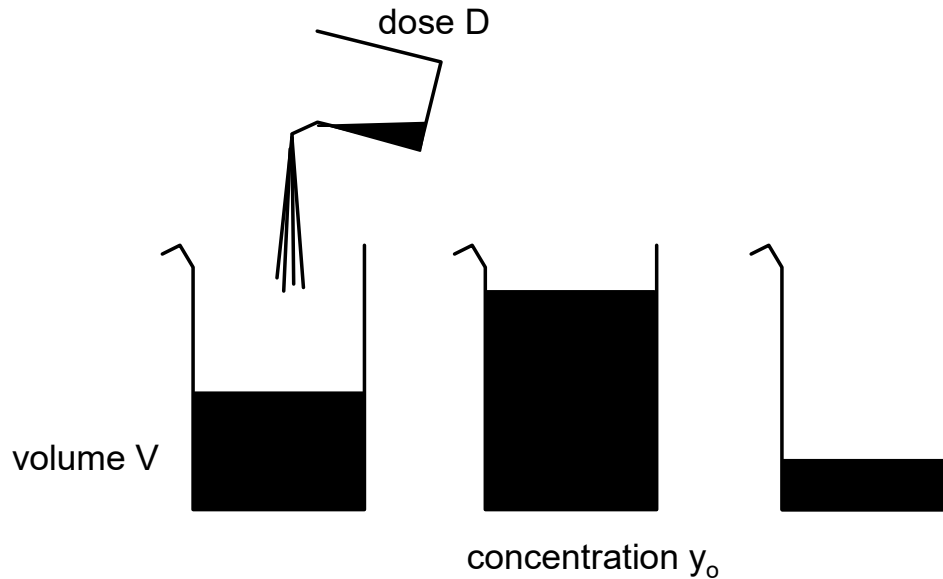

$$y_0 = \frac{D}{V}$$

The dosage depends on the volume of distribution

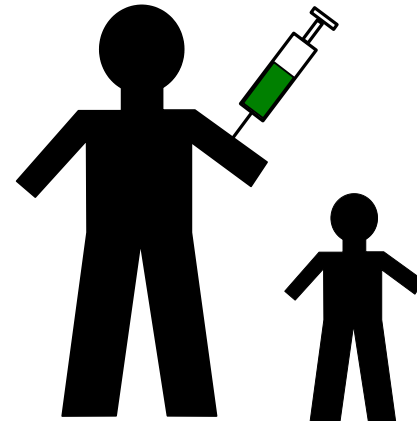

Invasion / systemic exposure

The full concentration can only be achieved by intravenous application. Otherwise invasion and elimination interact. This corresponds physico-chemically to subsequent reaction.

$$[A]_t = [A]_0 \frac{k_{Inv}}{k_{Inv} - k_{El}} \left(e^{-k_{El}t} - e^{-k_{Inv}t} \right) \quad \text{Bateman function}$$

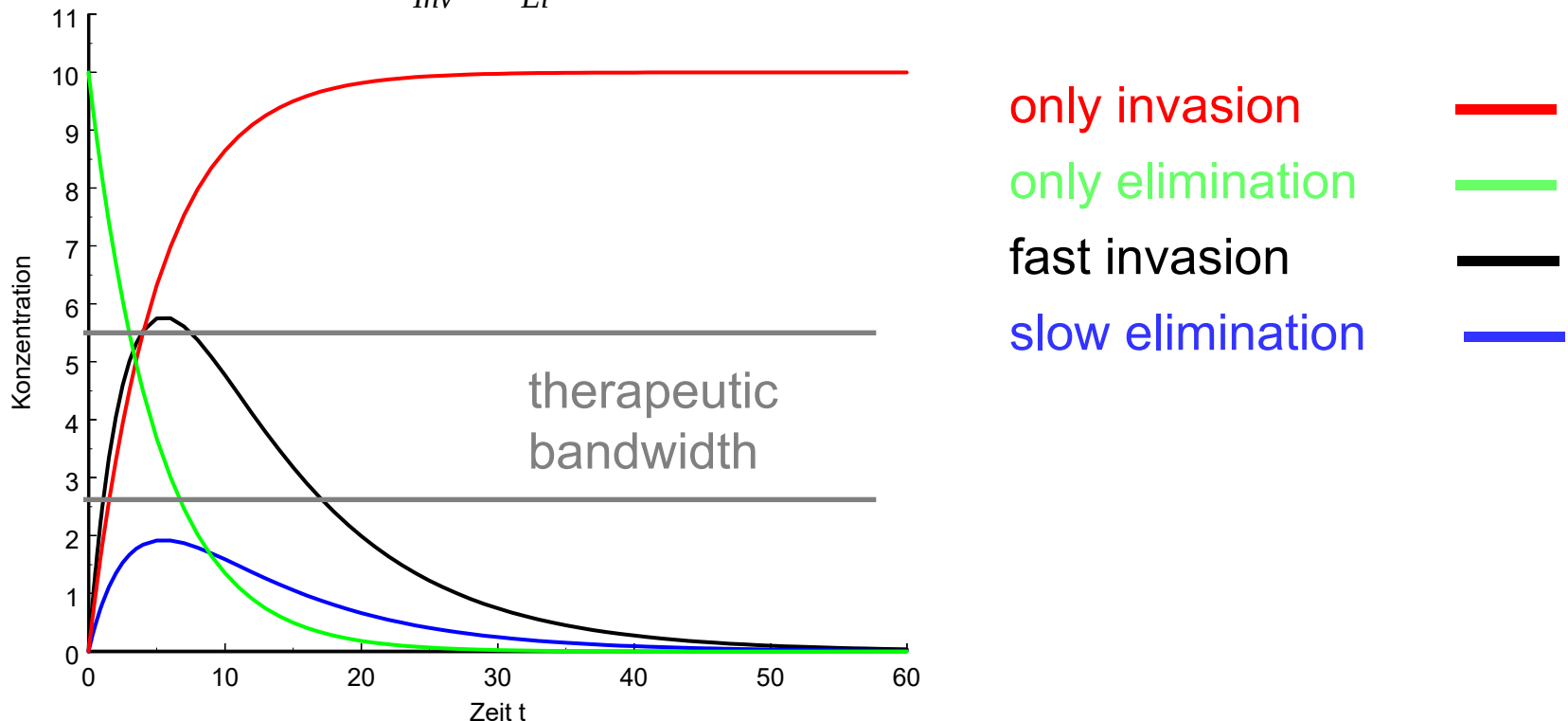

The principle of Dost (I)

Dependence of the concentration profile for different dosage

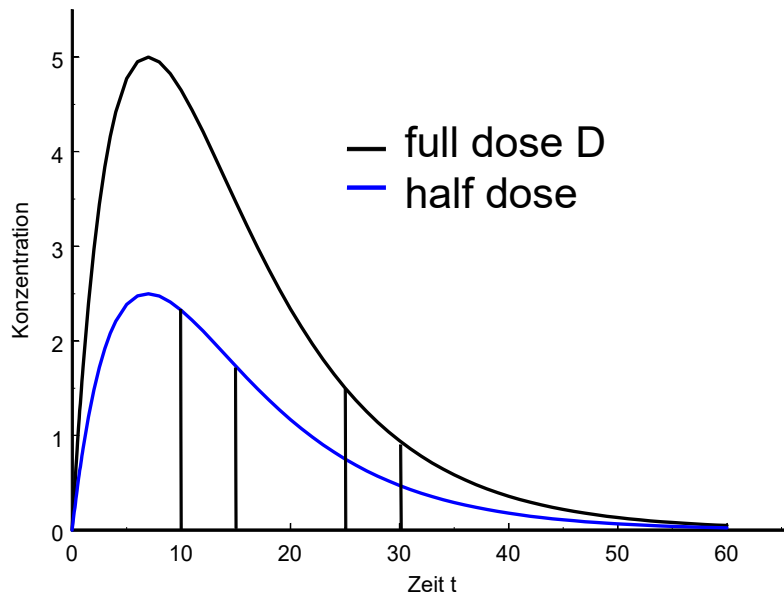

Between two sample points, the area S (transit) below the curve can be obtained by integration of the Bateman function as:

$$S = \frac{D}{Cl_{tot}}$$

Total clearance: volume that is cleared per unit of time

$$Cl_{tot} = \frac{\ln 2}{t_0} V \text{ [volume/time]}$$

Corresponding areas correspond to the ratio of the doses

The principle of Dost (II)

The reference curve is obtained by intravenous application of the dose

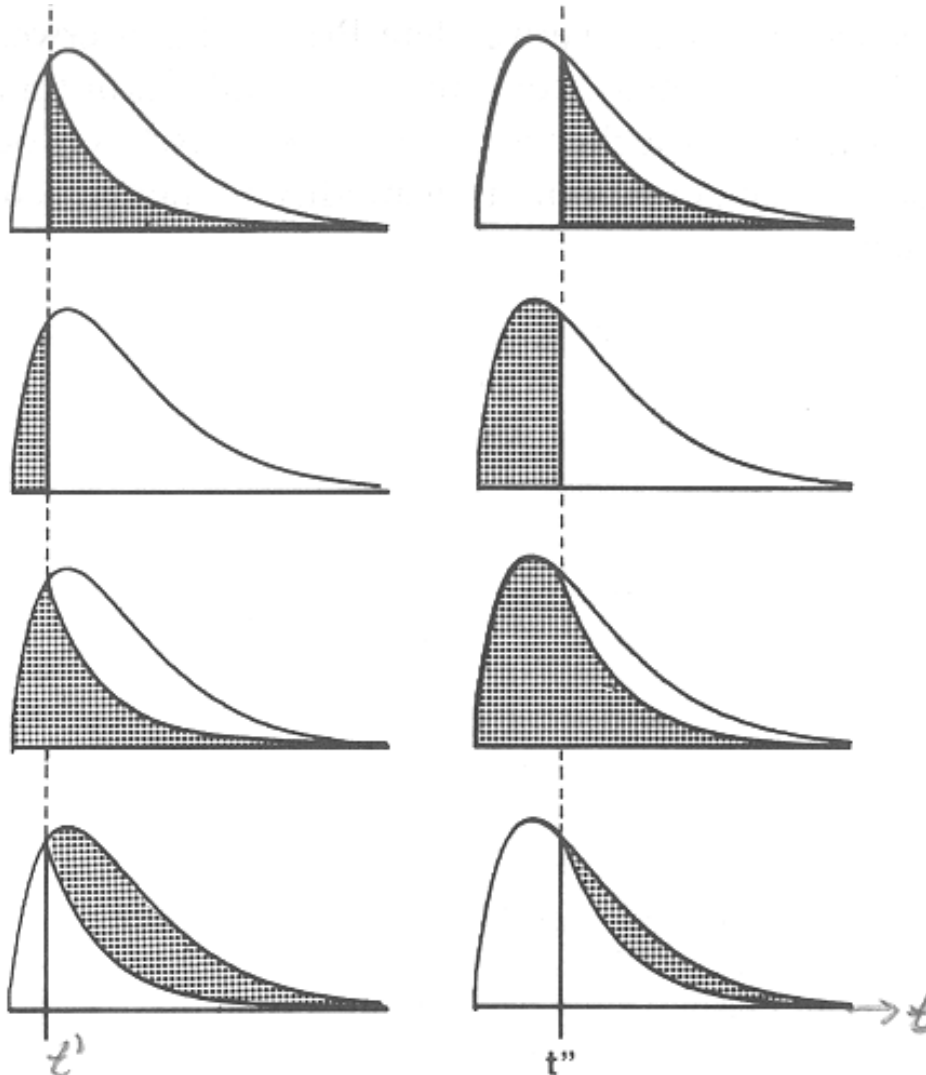

occupancy
= measurable
concentration

transit
= already irreversible
eliminated amount

transfer
= occupancy + transit
= absorbed amount

availments
= amount that is still
available for invasion

Experimental data for pharmacokinetic models

chemical data

partition coefficients
metabolic turnover rates

V_{\max} , K_m , K_i

solubility

vapour pressure

diffusion constant

protein binding constants

biological data

anatomic dimensions

flow of blood through
the organs

volume of organs

respiration

body mass

age, gender

extent of physical activity

Pharmacokinetic models (I)

Compartment models

assumption:

no metabolic conversion inside the compartments

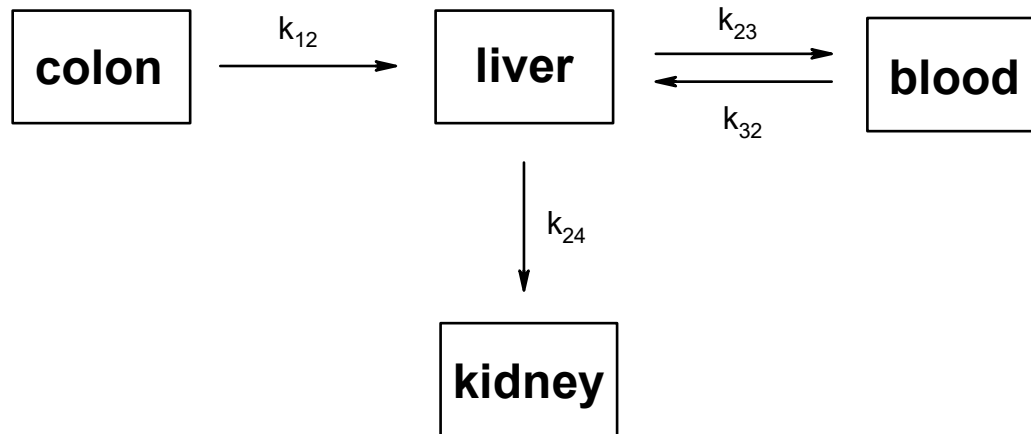

The concentration profile with time can be calculated by using linear differential equations

Lit: J.E.W.Beneken, J.H.van Oostrom „Modeling in Anesthesia“, *Journal of Clinical Monitoring and Computing* **14** (1998) 57-67.

Pharmacokinetic models (II)

Systemic blood circulation as electric network (1930)

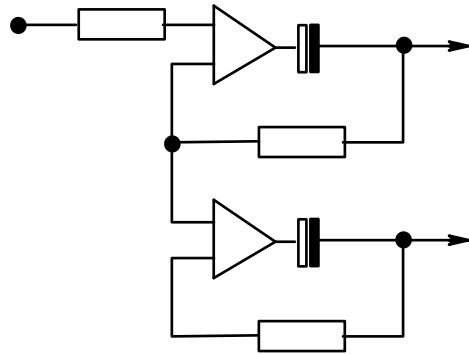

Simulation via analog computers (patch cords between the modules, resistors, capacitors)

applicability: inhalative anesthetics (low metabolic conversion, lipophilic, are exhaled)

Lit: G.Fleischli, E.N.Cohen *Anesthesiology* **27** (1966) issue 1, 64-69.

Distribution

From within the plasma the drug has to reach other compartments, depending on its target.

Substances that act on the central nervous system (CNS) have to cross the blood-brain barrier. Conversely, other drugs should not pass this barrier.

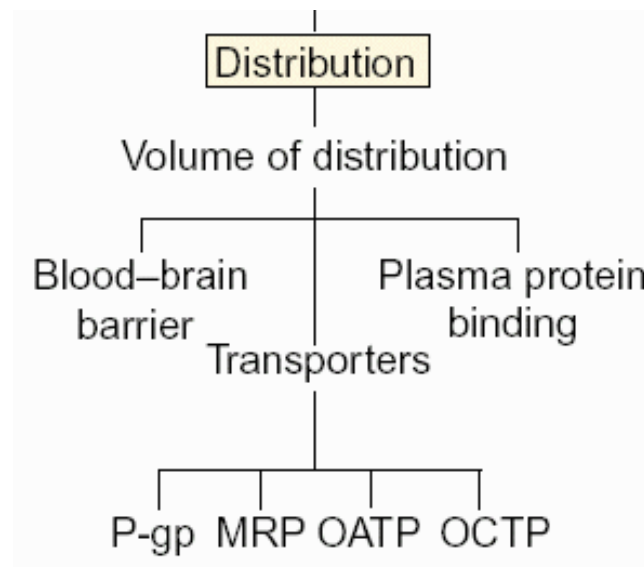

Besides passive diffusion, active transport has to be considered. Charged and polar substance require active transport.

Plasma protein binding / Distribution

The available concentration of drugs can be reduced due to binding to other proteins. This occurs in the plasma, the extracellular and interstitial fluid.

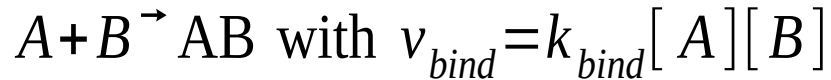

In the equilibrium state no change is measurable, thus

$$k_{bind} [A][B] = k_{diss} [AB]$$

$$K = \frac{[AB]}{[A][B]} = \frac{k_{bind}}{k_{diss}}$$

Binding proceeds according to the Langmuir's absorption isotherm (the heat of absorption is independent from the degree of coverage) and therefore fulfills the law of mass action [Massenwirkungsgesetz]

Besides proteins also mucopolysaccharides (binding- and supporting tissue (stroma)) can absorb substances.

Metabolism (I)

(bio-)chemical reactions of xenobiotics in the body

First pass effect:

Extensive metabolization of mainly lipophilic molecules, such with $MW > 500$, or those that have a specific affinity to certain transporters, during the first passage through the liver

Phase I:

Oxidation, reduction and hydrolysis
esp. Cytochrome P450 enzymes

Phase II:

Conjugation with small molecules (e.g. glutamine)

Phase III:

elimination by transporters

Metabolism (II)

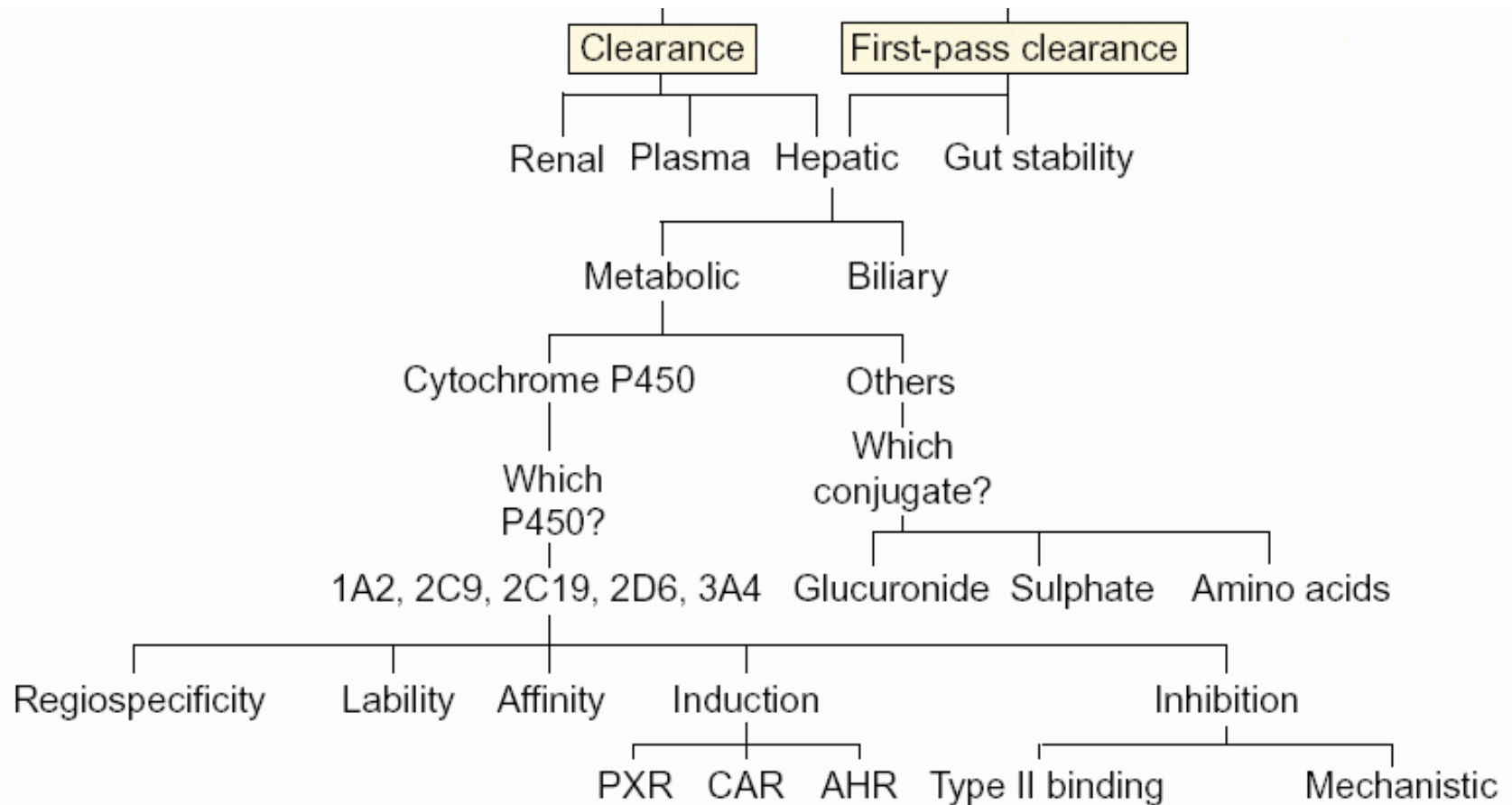

experimental (*in vitro*) methods:

human liver microsomes, hepatocytes and recombinant P450 enzymes (expressed in *E. coli*, or yeast cells)

Elimination / Excretion

Elimination comprises all processes that lead to removing of a substance from a compartment. These can also be of **metabolic** nature.

Lipophilic substances can be excreted using bile [Gallensaft], hydrophilic compounds via urine.

In general:

MW <300	300-500	>500
bile	bile & urine	urine

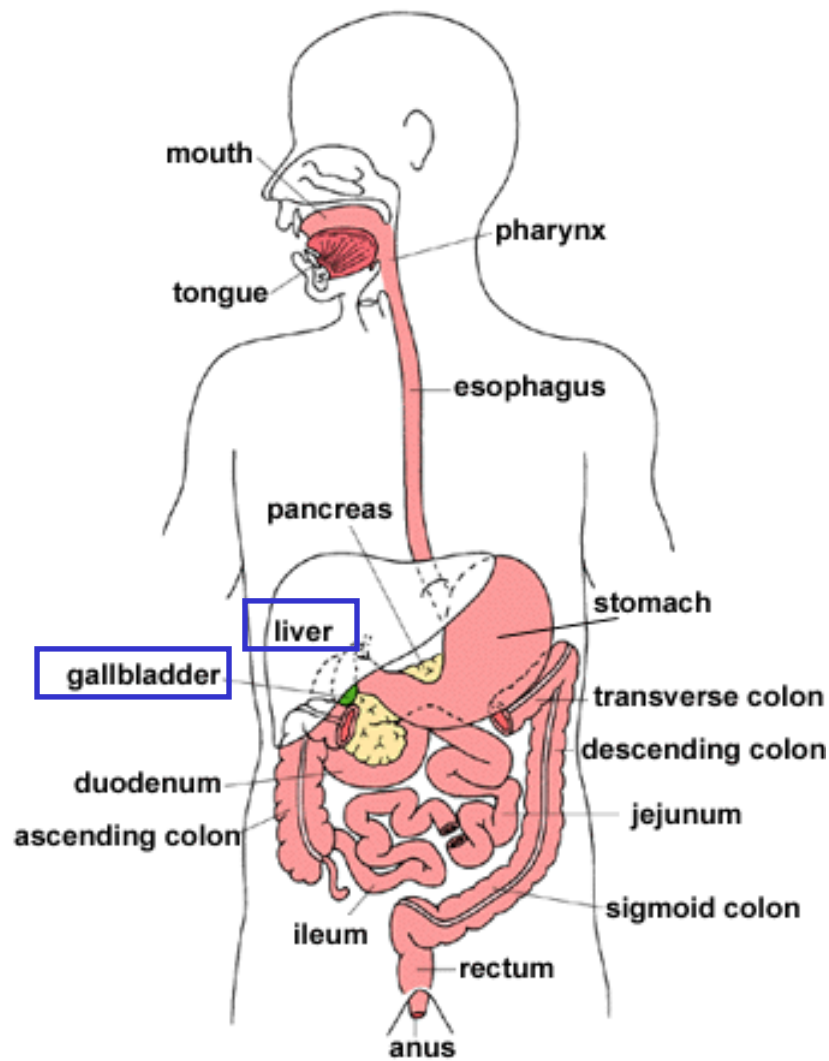

Elimination / Clearance

Metabolic paths (overview)

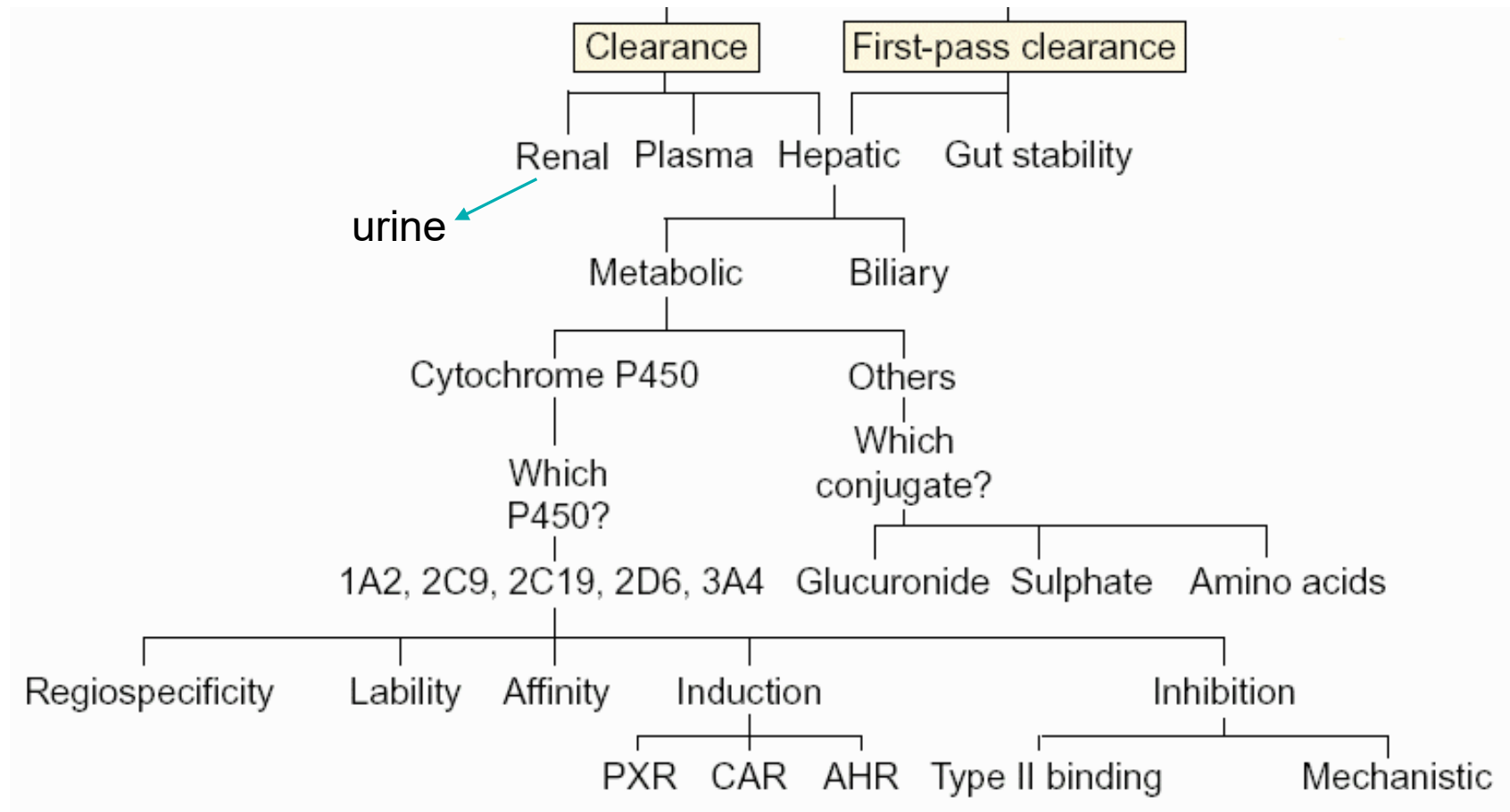

Elimination / Clearance (III)

From the physico-chemical point of view, elimination of a substance is a 1st order decay process (depending on the present concentration of the compound)

$A \rightarrow B$ with $v = k[A]$ k rate constant of elimination

$\frac{-d[A]}{dt} = k[A]$ $\left| \cdot \frac{dt}{[A]} \right.$ and integration leads to

$$-\int_{[A]_0}^{[A]_t} \frac{d[A]}{[A]} = \int_0^t k dt \quad \text{or} \quad \ln \frac{[A]_t}{[A]_0} = -kt \quad \text{or}$$

$$[A]_t = [A]_0 e^{-kt}$$

with the half life $t_{1/2} = \frac{\ln 2}{k}$

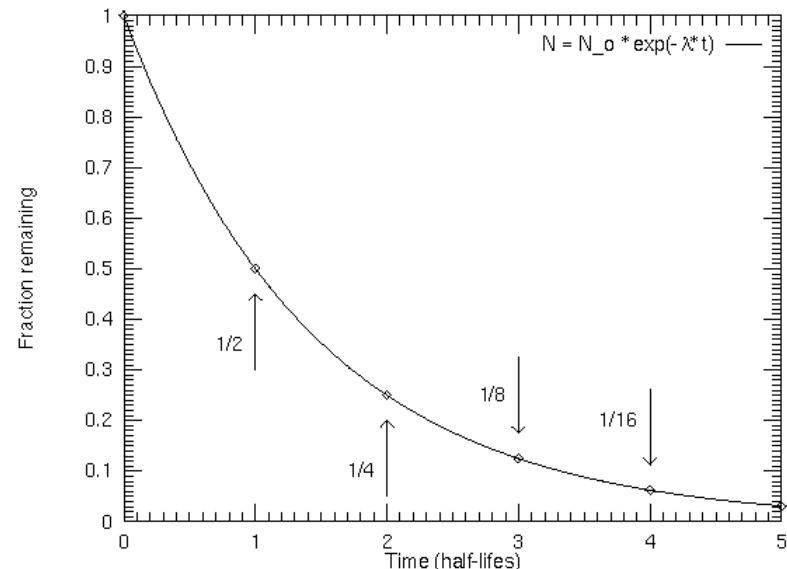

The blood-brain barrier (BBB)

Cross section through a capillary vessel

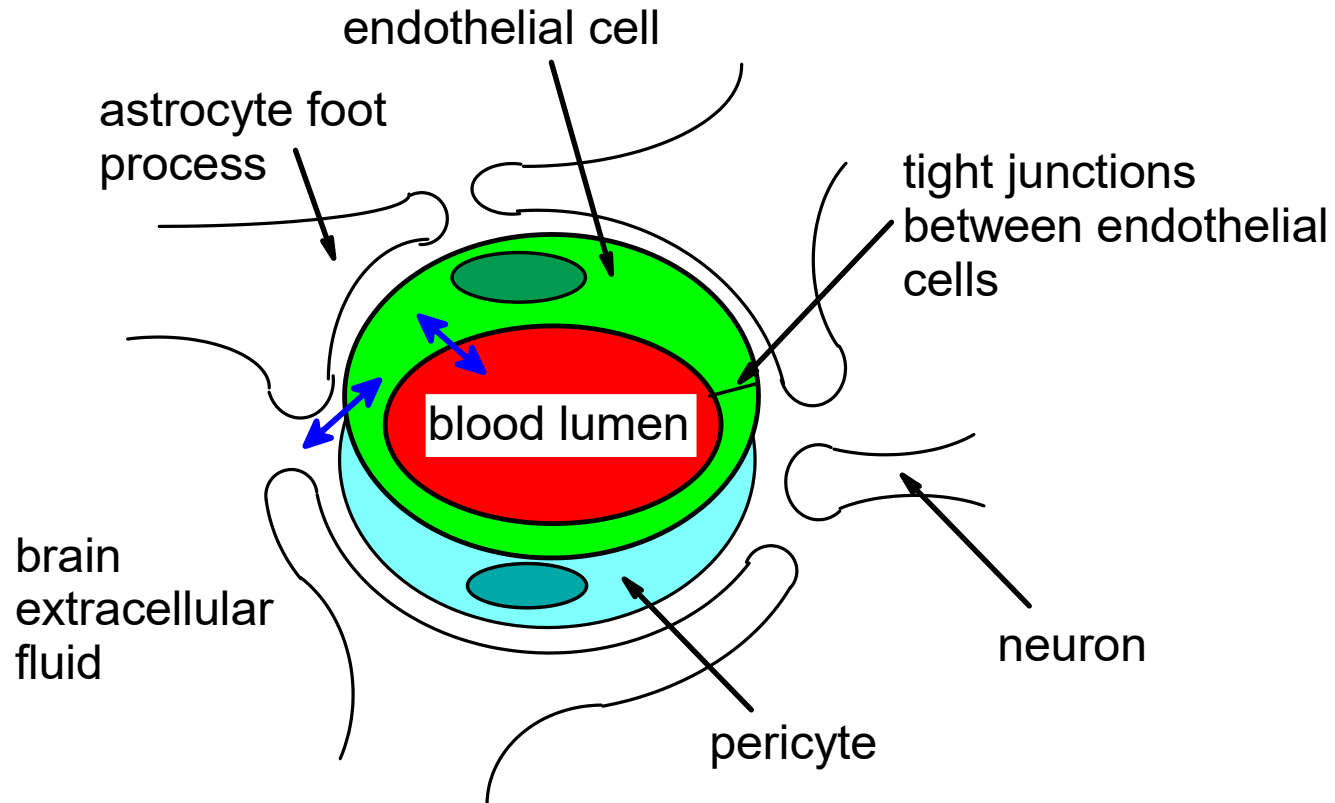

According to: J.-M. Scheerman in *Pharmacogenomics*,
J.Licinio & Ma-Li Wong (Eds.) Wiley-VCH (2002) pp. 311-335.

Function of the blood-brain barrier

in silico prediction of the blood-brain barrier permeability in the course of pre-clinical development is particularly important, since

- only substances that shall act on the central nervous system (CNS), should pass the blood-brain barrier effectively.
- BBB-screening is particular „expensive“ (testing on animals not avoidable: microdialysis, isotope labeling)
- models using artificial membranes (endothelial cells) are still in development.

Blood-Brain Barrier (II)

As a measure for the permeability of the blood-brain barrier, the logarithmic ratio of the concentrations is used

$\log\text{BB} = \log([\text{brain}]/[\text{blood}])$ range: -2.00 to $+1.00$

Mainly in the blood $-1.0 < \log\text{BB} < 0.3$ mainly in the brain

It can be assumed that the $\log\text{BB}$ has been determined for about 300 drugs, only. However, for much more compounds a qualitative assignment (CNS+ or CNS–) is known.

Lit. D. E. Clark, *J. Pharm. Sci.* **8** (1999) 815

Blood-Brain Barrier (III)

In contrast to the absorption from the duodenum, the polarity of the compounds that cannot be described by the PSA comes into account. Example:

	PSA	logBB	ClogP	polarizability (AM1)
benzene	0	-0.69	2.1	1
3-methylpentane	0	2.01	3.7	14.8

An according QSPR equation was derived

$$\log\text{BB} = a \text{ PSA} + b \text{ ClogP} + c \quad \text{with } r = 0.887$$

Lit. D. E. Clark, *J.Pharm.Sci.* **8** (1999) 815

F. Lombardo et al. *J.Med.Chem.* **39** (1996) 4750

Formerly used descriptors

Each of these terms is correlated to logBB by itself:

- logP fragment based (MlogP, ClogP,...)
- Polar surface area contributions from N, O and H atoms
- hydrogen-bond donors and acceptors numerical count
- size and shape molecular volume and globularity

Descriptors for size and shape

Connected to the shape of the molecule are:

Molecular volume, globularity, number of rotatable bonds

globularity:

Ratio of the surface (assuming the molecule would be a perfect sphere) to the actual surface. Always < 1

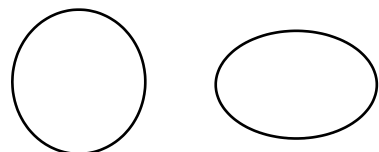

Principle components of the molecular geometry:

3D extension of the molecule in space

New descriptors for size and shape

- Descriptors such as the globularity are correlated to the molecular weight and the number of hydrogen atoms
- + Replaced by three terms derived from the molecular geometry

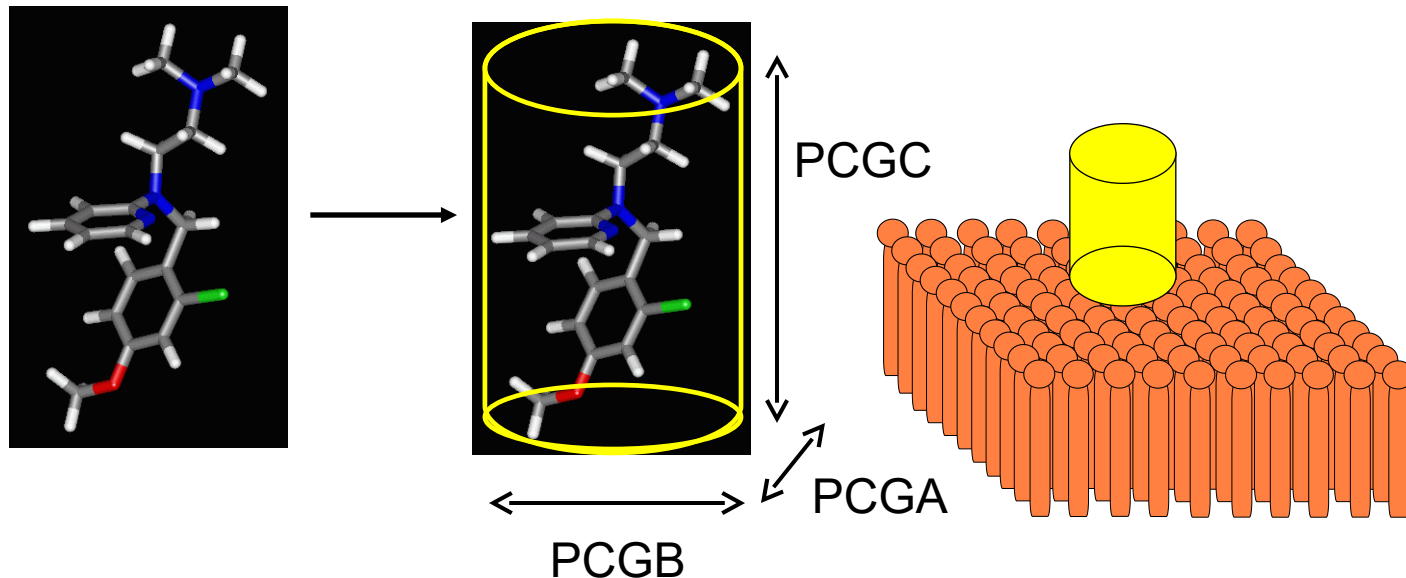

BBB-model with 12 descriptors

Descriptors mainly from QM calculations: electrostatic surface, principal components of the geometry, H-bond properties

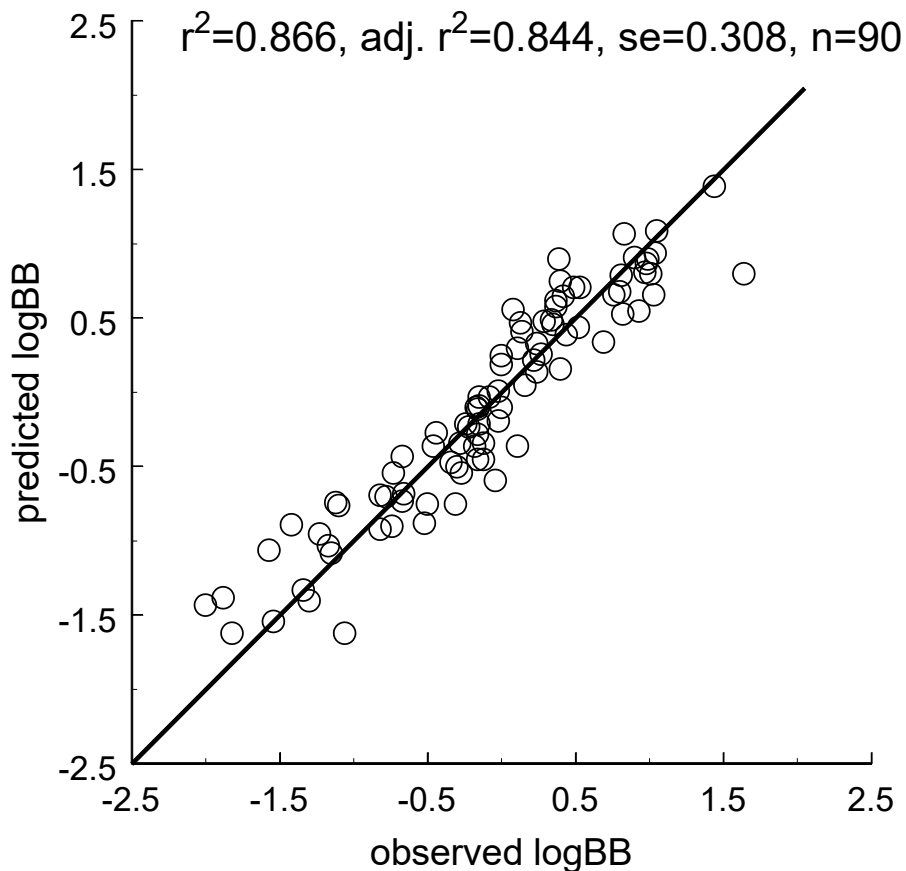

Lit: M. Hutter *J.Comput.-Aided.Mol.Des.* **17** (2003) 415.

Web-based online tools

A number of institutes and companies have put up servers for the prediction of ADME related properties.

Usually these apply Java-applets that allow drawing molecules, allow input either as SMILES string or one of the many 3D coordinate files.

A summary including hyperlinks is offered by the *Virtual Laboratory*

<http://146.107.217.178/online.html>

Lit. I.V. Tetko, *Mini Rev.Med.Chem.* **8** (2003) 809.

I.V. Tetko et al., *J.Comput.-Aided Mol.Des.* **19** (2005) 453.